

Arctic Cat Ski Runner (2007-2018) Installation Instructions

To replace your stock runner, use Woody's® 9975 Dooly™, Slim Jim® or single runner. The 9975 series, which has 4 bolts, will fit your ski whether your ski has 3 or 4 bolt holes. If your ski has 4 bolts holes, install per the instructions with the runner. If your ski has 3 bolt holes, you will need to make a ski modification to accommodate an additional mounting bolt. These instructions are applicable if you are installing a Dooly™, Slim Jim® or a single runner from the 9975 series as the bolt pattern is the same.

If you choose to remove the ski to make this modification, refer to the instructions for ski removal in your snowmobile owner's manual.

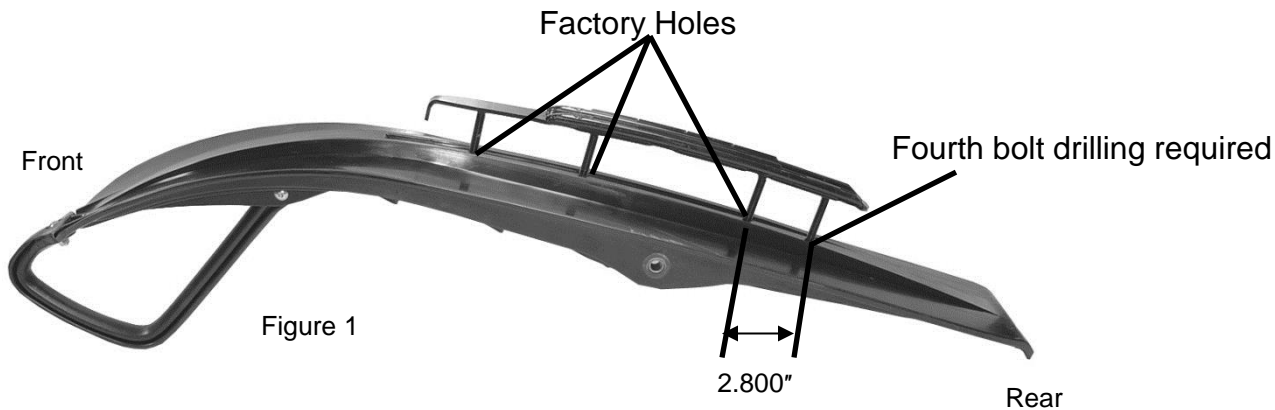

To install a Woody's 9975 series runner, which has a 4 bolt pattern, on a 3 bolt ski you will need to make the following modification to the ski. Please follow the important instructions below. If you have any questions, contact your snowmobile dealer or contact Woody's at www.WoodysTraction.com.

The ski modification you will need to make is an additional hole at the rear of the ski.

- 1) Place the 9975 series runner in the 3 bolt holes on the bottom of the ski. The fourth bolt will contact the ski at the point where the additional bolt hole will need to be drilled. (Figure 1) At this point using a marker place a mark on the keel at the center of the fourth bolt. (Figure 2) Or you can measure from the center of the bolt nearest the rear of the ski 2.800" to determine the new bolt hole placement. (Figure 3)
- 2) On the mark you have made to indicate the fourth hole placement, bore a hole through the ski using a 25/64"-drill bit. (Figure 4)
- 3) Install the Woody's® 9975 series runner by following the installation instructions provided in the package.

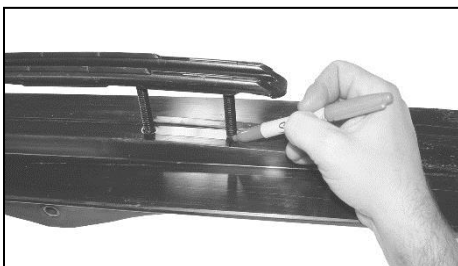

Figure 2

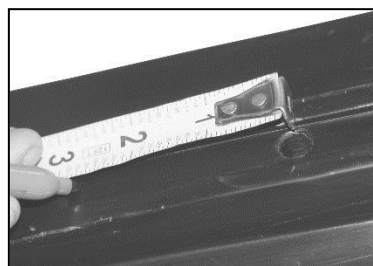

Figure 3

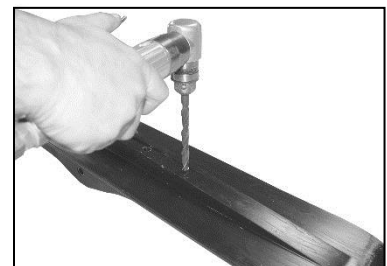

Figure 4

Review the snowmobile manufacturer's instructions to install runners in your owner's manual. You may void your warranty if their recommendations are not followed. Be certain to inspect the ski and/or runner for damage prior to installation. Failure to follow all of the above instructions will void any and all warranties of IEM.